

REV	DESCRIPTION	DRAWN	DATE

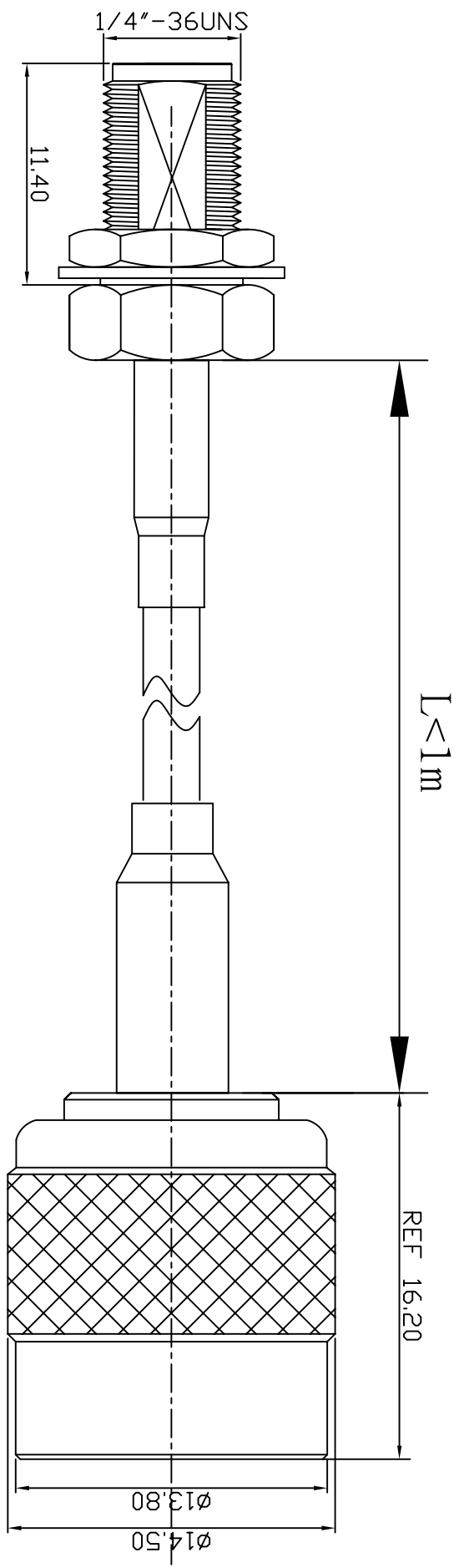

$L < 1\text{ m}$

REF 16.20

$\phi 13.80$
 $\phi 14.50$

NO	Description	Qty	Material	Finish
3	TNC-1501-4-F-TGN	1	BRASS	NICKEL
2	LLC200/RG58	1		
1	SMA-1012-33-F2-TGG	1	BRASS	GOLD

UNLESS OTHERWISE SPECIFIED		*MAJOR DIMENSION	
1 REMOVE ALL BURRS		UNLESS OTHERWISE	
2 BREAK ALL CORNERS & EDGES CO.15 MAX.		NOTED TOLERANCES	
3 CHAMFER 1:1 & LAST THREADS 45°		0.5-6 = ±0.2	
4 DIAMETERS ON COMMON CENTERS		6-30 = ±0.4	
5 ALL DIMENSIONS ARE AFTER PLATING.		30-120 = ±0.6	
		120-315 = ±1.0	
		ANGLES = ±1°	

SCALE	7/2	UNIT	MM
-------	-----	------	----

APPROVED	CHECKED	DRAWN	DRAWN DATE
		ARNQ	03/06/21

華耀科技有限公司 <i>Hua Yao Technologies co.,Ltd</i>	
TITLE	SMA1012-TNC1501
DRAWING NO.	101233/200/58/15014-1L
REV	A

FILE NO.	D:\DWG\SMA1012-TNC1501\101233/200/58/15014-1L
----------	---