

REV	DESCRIPTION	DRAWN	DATE

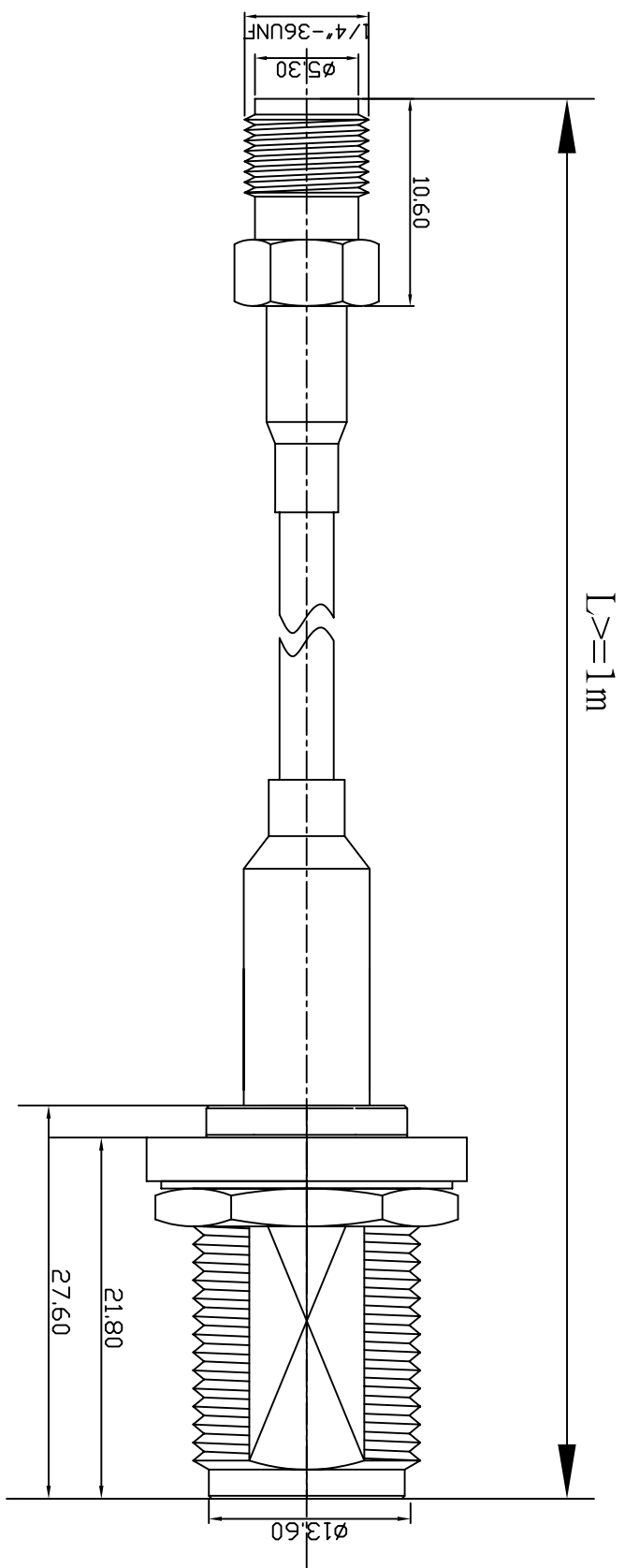

L >= 1 m

NO	Description	Qty	Material	Finish
3	N-1159-1-L-TGN	1	BRASS	NICKEL
2	RG174/RG316/LC100	1		
1	SMA-1011-1-L-TGG	1	BRASS	GOLD

UNLESS OTHERWISE SPECIFIED
 1 REMOVE ALL BURRS
 2 BREAK ALL CORNERS & EDGES CO.15 MAX.
 3 CHAMFER 1ST & LAST THREADS 45°.
 4 DIAMETERS ON COMMON CENTERS TO BE CONCENTRIC WITH DIMENSIONS ARE AFTER PLATING.

*MAJOR DIMENSION
 UNLESS OTHERWISE NOTED TOLERANCES
 0.5-6 = ±0.2
 6-30 = ±0.4
 30-120 = ±0.6
 120-315 = ±1.0
 ANGLES = ±1°

APPROVED
 CHECKED
 DRAWN PEN
 DRAWN DATE 04/09/29

華耀科技有限公司
Hua Yao Technologies co.,Ltd
 TITLE SMA1011-N1159
 DRAWING NO. 10111/174/316/100/11591-AL
 REV A
 FILE NDD\DWG\SMA1011-N1159\10111/174/316/100/11591-AL