

REV	DESCRIPTION	DRAWN	DATE

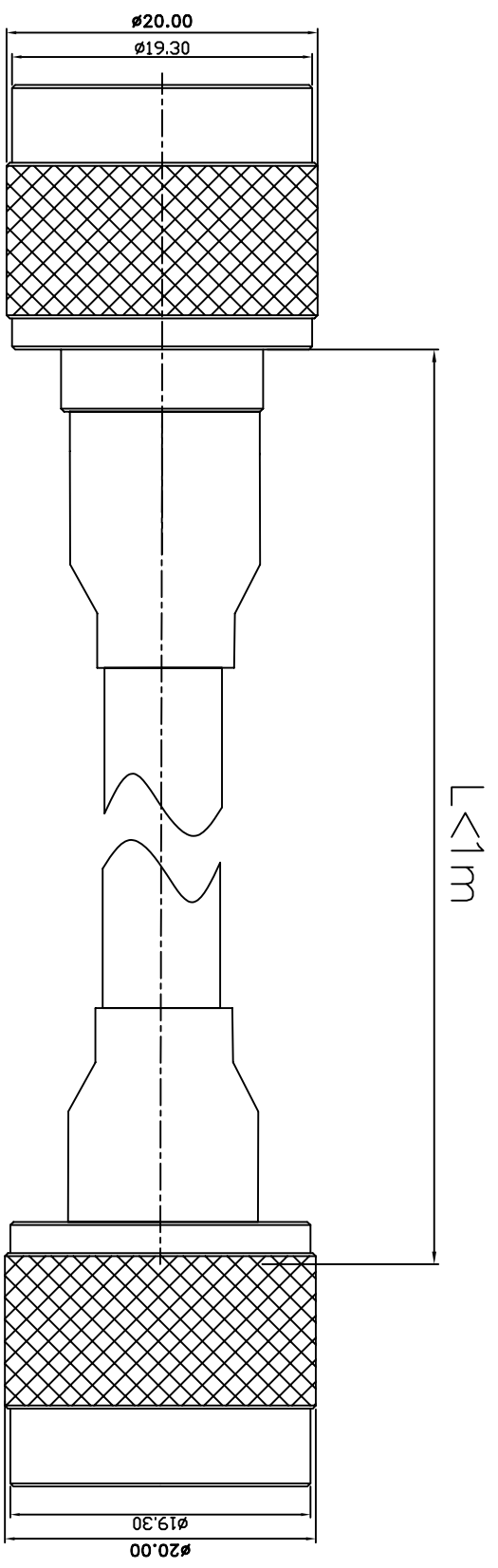

NO	Description	Qty	Material	Finish
3	N-1101-7-B4-TGN	1	BRASS	NICKEL
2	LOW LOSS 400	1		
	N-1101-7-B4-TGN	1	BRASS	NICKEL

1 REMOVE ALL BURRS 2 BREAK ALL CORNERS & EDGES CO.15 MAX. 3 CHAMFER 1ST & LAST THREADS 45°. 4 DIAMETERS ON COMMON CENTERS TO BE CONCENTRIC WITH DIMENSIONS ARE AFTER PLATING. 5 ALL DIMENSIONS ARE AFTER PLATING.		*MAJOR DIMENSION UNLESS OTHERWISE NOTED TOLERANCES 0.5-6=±0.2 6-30=±0.4 30-120=±0.6 120-315=±1.0 ANGLES=±1°		APPROVED CHECKED DRAWN PEN		TITLE N1101-N1101 Hua Yao Technologies co.,Ltd	
SCALE	3/1	UNIT	MM	DRAWN DATED	05/05/04	FILE NO.	D:\DWG\N1101-N1101\1101740011017-IL
華耀科技有限公司 Hua Yao Technologies co.,Ltd				DRAWING NO. 1101740011017-IL			
REV A				REV A			